



Loading arm TD

Land loading arms

Our TD model is a land loading arm with a parallel pipe design. We've developed it for embarking road or rail tankers, as well as the simultaneous removal of gases produced in the container.

Features

- Swivel joint model 3-2ST
- Product pipe in carbon steel, low temperature carbon steel or stainless steel
- Available in 2", 3", 4", 6", 8"
- Working pressure up to 40 bar
- Spring balancing
- Support of first length

Options

- Swivel joint model 4-2ST
- PTFE lining for chemical applications
- Loading valve
- Jacket or electrical heating + insulation
- Vacuum breaker
- Pneumatic/hydraulic operation
- Vapour return line
- Cone

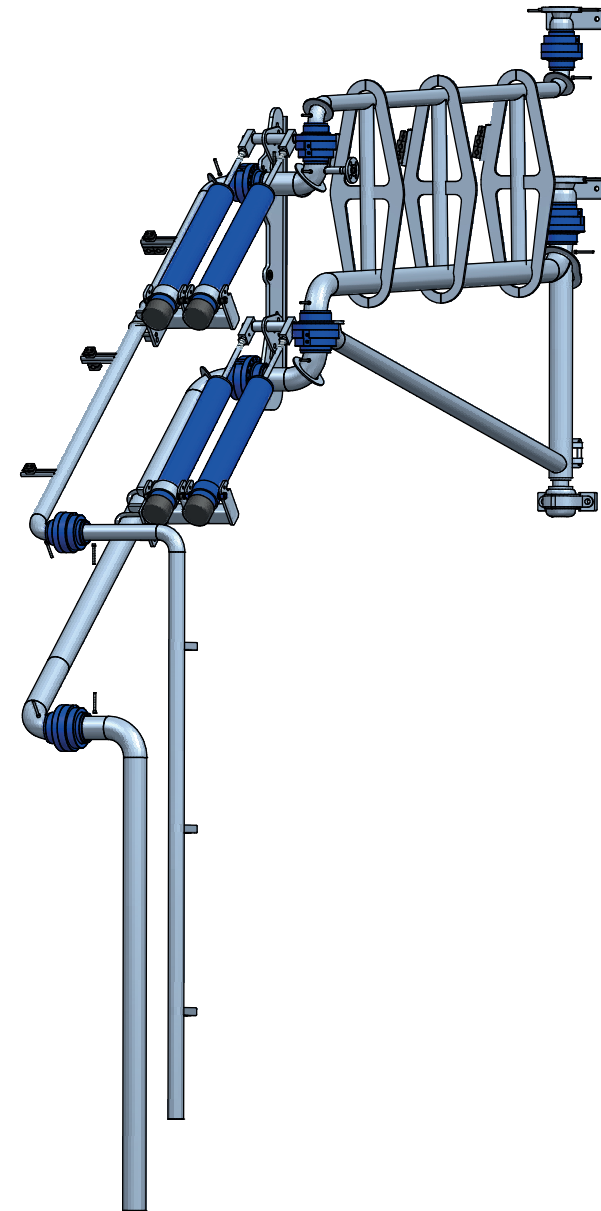

Wiese Europe bvba

Smederijstraat 16
2960 Brecht
Belgium

+32 3 633 16 10

info@wiese-europe.com
www.wiese-europe.com





Loading arm TK

Land loading arms

Our TK land loading arm can be used for all liquid and gaseous products. The TK land loading arm is used for a wide range of applications. This is the first choice for long ranges, because it has the ability to cover up the complete truck.

Features

- Swivel joint model 3-2ST
- Product pipe in carbon steel, low temperature carbon steel or stainless steel
- Available in 2", 3", 4", 6", 8"
- Working pressure up to 40 bar
- Spring balancing
- Support of first length

Options

- Swivel joint model 4-2ST
- PTFE lining for chemical applications
- Loading valve
- Jacket or electrical heating + insulation
- Vacuum breaker
- Pneumatic/hydraulic operation
- Vapour return line
- Cone
- Piggable

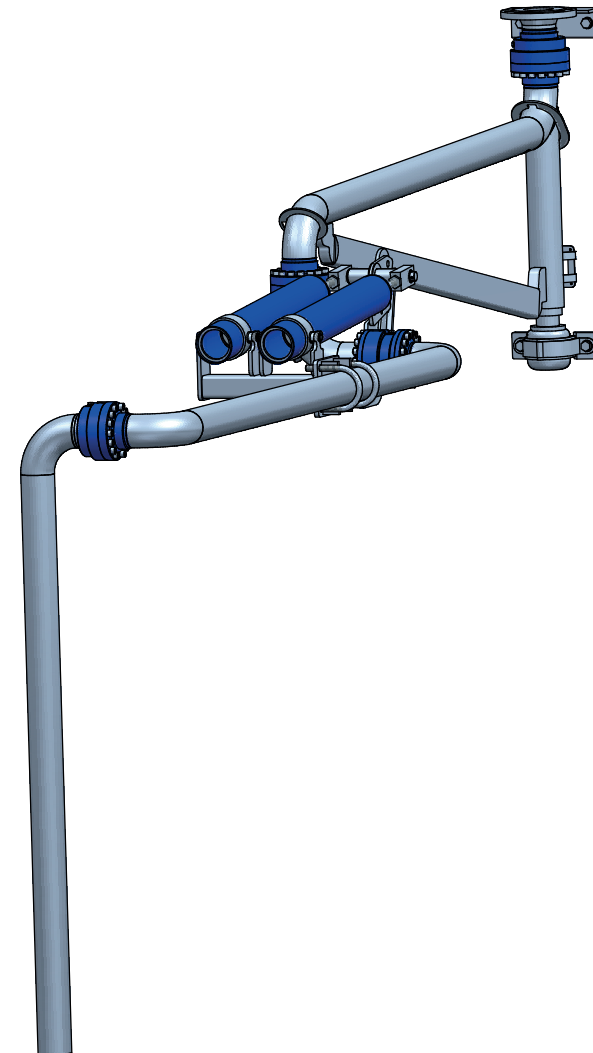

Wiese Europe bvba

Smederijstraat 16
2960 Brecht
Belgium

+32 3 633 16 10
info@wiese-europe.com
www.wiese-europe.com





Bottom loading station TM2

Land loading arms

Features

- Swivel joint model 3-2ST
- Product pipe in carbon steel, low temperature carbon steel or stainless steel
- Available in 2", 3", 4", 6", 8"
- Working pressure up to 40 bar
- Spring balancing
- Support of first length

Options

- Swivel joint model 4-2ST
- PTFE lining for chemical applications
- Loading valve
- Jacket or electrical heating + insulation
- Pneumatic/hydraulic operation
- Vapour return line
- Emergency breakaway coupler
- A wide variety of couplers

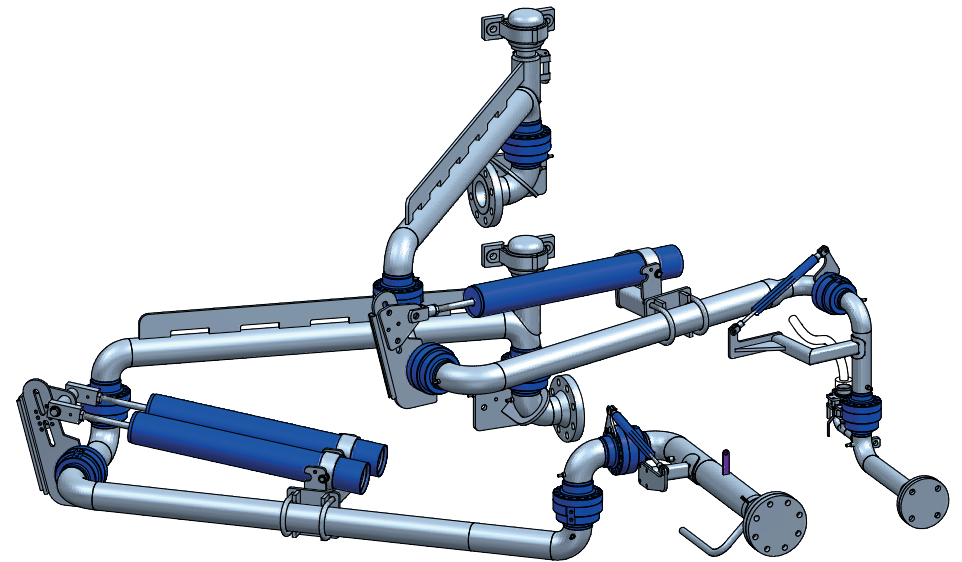

Wiese Europe bvba

Smederijstraat 16
2960 Brecht
Belgium

+32 3 633 16 10

info@wiese-europe.com
www.wiese-europe.com





Loading arm TP

Land loading arms

Our TP land loading arm can be used for all liquid and gaseous products.

The TP land loading arm is used for short reach and installation without additional support.

Features

- Swivel joint model 3-2ST
- Product pipe in carbon steel, low temperature carbon steel or stainless steel
- Available in 2", 3", 4"
- Working pressure up to 40 bar
- Spring balancing

Options

- PTFE lining for chemical applications
- Loading valve
- Jacket or electrical heating + insulation
- Vacuum breaker
- ...

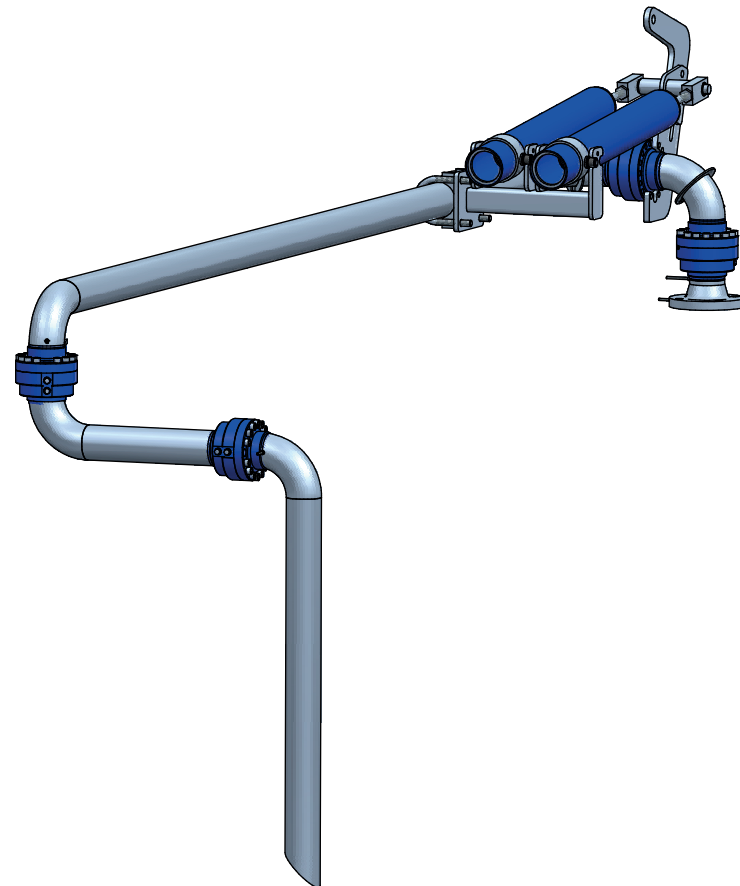

Wiese Europe bvba

Smederijstraat 16
2960 Brecht
Belgium

+32 3 633 16 10
info@wiese-europe.com
www.wiese-europe.com

